

The Viable System Model

Trevor Hilder

Cavendish Software Ltd.

(Presentation v1.03 12-Jun-1995)

© Cavendish Software Ltd. 1995, portions © Stafford Beer 1985

This presentation provides a brief introduction to Stafford Beer's Viable System Model (VSM).

Stafford Beer is one of the leading figures in the science of *cybernetics*, which concerns itself with the underlying laws which govern how organisms, machines and organizations maintain their identity, and fulfill their purposes within their environment.

Cybernetics claims that there are underlying laws which apply equally to the manner in which the nervous system of an animal maintains control over its actions, to the way in which a species maintains itself within its ecosystem, and to how a corporation maintains its existence in its marketplace.

The VSM provides a notation which can be applied by non-mathematicians to help them understand and apply these general laws.

Objective

- *To provide a brief introduction to Stafford Beer's Viable System Model*
 - ◆ *Its purpose*
 - ◆ *How it can be used*

© Cavendish Software Ltd. 1995, portions © Stafford Beer 1985

Stafford Beer developed the VSM over a period of over thirty years as an aid to the practical process of diagnosing problems in human organizations, and helping to improve their functioning.

Stafford believes that effective organizations should maximize the freedom of their participants, within the practical constraints of the requirement for those organizations to fulfill their *purpose*.

He believes that the science of cybernetics can be used to *design* organizations which fulfill these objectives. The VSM is intended to act as an aid to the process of diagnosis of organizational problems, and the subsequent process of organizational re-design. The re-designing process should use technology, particularly information technology, to assist in providing organizations with a nervous system which supports their aims, without the burden of bureaucracy.

Intended Audience - 1

- *Intelligent laymen interested in “How things **really** work” and how they could work better*
 - ◆ *Why do our organizations have so much trouble meeting their objectives?*
 - ◆ *Why are they in constant crisis?*
 - ◆ *Why doesn't reorganization improve things?*

© Cavendish Software Ltd. 1995, portions © Stafford Beer 1985

Most of us know very little about how the organizations which influence our lives actually function. This is because we lack any but the most rudimentary concepts for thinking about them.

The answers to the questions above will not be answered directly in this presentation. Consider them as an exercise for the student!

Intended Audience - 2

■ *Technologists who want to use IT to increase the effectiveness of organizations, while enhancing the “freedom” of the participants*

◆ *Why do many IT systems increase the bureaucratic burden on workers, rather than decrease it?*

◆ *Why is it so hard to manage software projects effectively?*

© Cavendish Software Ltd. 1995, portions © Stafford Beer 1985

IT systems are often designed without a clear examination of the workings of the organization which they are intended to serve. This can easily lead to the automation of processes which do not meet the needs of that organization.

Software projects often involve the management of a very high degree of complexity. All too frequently, complex issues are oversimplified to fit assumptions about how projects need to be structured. Once broken down into “simple” parts, work can proceed, with apparent progress. Unfortunately, when the attempt is made to integrate the parts together near the end of the project, the discovery is made that “the sum of the parts does not equal the whole”.

The Viable System Model provides a useful framework for an understanding of how to overcome these common difficulties.

Intended Audience - 3

- *Those interested in new methods of organizing work*
 - ◆ *Telecommuting*
 - ◆ *Virtual Companies*
 - ◆ *Business Process Re-engineering*
 - ◆ *The Intelligent Organization*

© Cavendish Software Ltd. 1995, portions © Stafford Beer 1985

New methods of organizing work, particularly those which use telecommunications and information technology to distribute work amongst geographically separated workers, require a radical re-examination of assumptions about organization.

The Viable System Model offers a set of “thinking tools” which facilitate this process. It may also be possible to use the Viable System Model to automate the process of designing the “nervous systems” of the new types of organizations which are now evolving.

The Problem in a Nutshell

■ *Human organizations are much more **complex** than we are usually prepared to admit*

Typical Organisation Chart

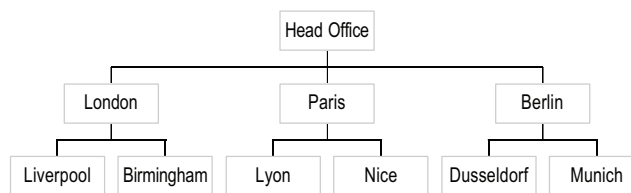

© Cavendish Software Ltd. 1995, portions © Stafford Beer 1985

Few of us think very deeply about what makes organizations “tick”. This is probably because human beings are very easily conditioned to accept the social framework around them as though it was a part of the natural world, and therefore no more under their control than the weather.

We may grumble about bad weather, but this does not lead most of us to investigate it. We assume there is nothing that can be done about it, so what point is there in studying it?

Before Isaac Newton, practically nobody thought there was any point in studying why apples fall to the ground. Newton’s thoughts on this apparently pointless subject, however, have revolutionized the world.

The study of organizations could have equally important consequences.

Organization Charts

- *Don't show how the organization **really** works*
- *Only say who is to blame when things go wrong*

© Cavendish Software Ltd. 1995, portions © Stafford Beer 1985

Organization charts reflect the human (at least, male!) need to think of social relations in terms of dominance hierarchies. This way of thinking probably has its roots in the prehistoric organization of hunting bands.

It does not tell us very much about the intricacies of the complex organizations which surround us.

Cybernetics

- *The science of communication and control in the animal and the machine (Norbert Wiener 1948)*
- *Broader definition:*
 - ◆ *The science of effective organization*

© Cavendish Software Ltd. 1995, portions © Stafford Beer 1985

The latter, more recent, definition describes the scope of the subject more accurately than Wiener's original definition.

The Concept of Variety

■ *Variety is the measure of the number of different states in a system*

■ *E.g.*

◆ *A light switch has a variety of 2*

● *States On & Off*

◆ *A single-digit display has a variety of 10*

● *States 0, 1, 2, 3, 4, 5, 6, 7, 8, 9*

© Cavendish Software Ltd. 1995, portions © Stafford Beer 1985

Note that these examples of variety assume that everything upon which the light or display depends is present and working properly! If the light bulb isn't working, the switch is broken, the wires are cut or the power is off, the light switch no longer has a variety of 2.

A dimmer switch obviously has a much higher variety than a simple on/off switch. If it can be off, or set to three brightness levels, it has a variety (assuming everything is working, again) of 4.

Getting more subtle, if the dimmer is continuously variable, its variety, for practical purposes, is determined by the *just noticeable difference* in brightness which can be observed when it is adjusted. The number of states it can be in depends on the *observer*.

The variety of a system therefore depends on the context in which it is embedded, and also who is observing that system.

The Concept of Variety

- *Variety grows rapidly with the complexity of systems*
 - ◆ *A two-digit display has a variety of 100*
 - ◆ *A three-digit display has a variety of 1000*
 - ◆ *An n-digit display, has a variety of 10^n*

© Cavendish Software Ltd. 1995, portions © Stafford Beer 1985

Again, this assumes that everything upon which the display depends is present and working properly.

The Concept of Variety

- *Real-world systems have variety which is effectively mathematically infinite*
 - ◆ *So how do we cope with “reality”?*

© Cavendish Software Ltd. 1995, portions © Stafford Beer 1985

How we cope with the staggering variety of stimuli which constantly assail us, is a key question in the study of perception.

Variety Attenuators

- *Our perceptual apparatus attenuates, or filters, the variety of our environment*
 - ◆ *We only “see” what we look for, and filter out what is “irrelevant”*



© Cavendish Software Ltd. 1995, portions © Stafford Beer 1985

The zig-zag symbol for an attenuator is borrowed from electronics.

Variety Attenuators

■ *Where do our variety attenuators come from?*

- ◆ *Our human physiology*
 - *Can't see infra-red or ultra-violet light*
- ◆ *Our individual endowments*
 - *Some of us are tone deaf*
- ◆ *Our social conditioning*
 - *Conditioning by our families, and our broader social environment*

© Cavendish Software Ltd. 1995, portions © Stafford Beer 1985

Our variety attenuators do not simply reduce the amplitude of the signals coming from the environment. If they did, they would be useless. They actually select aspects of the signals which are relevant, and discard aspects which are not. The question of what is relevant, and what is not, is inevitably value-laden.

In natural living systems, the attenuators have been “designed” by natural selection. For example, the eyes of frogs are excellent at tracking flies, and useless at admiring works of art.

Similar forces are at work in the business world. Companies whose attenuators filter out important information about their environment are more likely to go out of business than those which don't.

As Stafford Beer says, “The *lethal* variety attenuator is sheer ignorance.”.

Designing variety attenuators is a skilled business. Market research is an example of carefully designed variety attenuation.

Variety Amplifiers

- *We also amplify our own variety to increase our power over our environment*
- ◆ *We use our intelligence to amplify the effect of our actions*



© Cavendish Software Ltd. 1995, portions © Stafford Beer 1985

The triangular symbol for a variety amplifier is also borrowed from electronics.

In the natural world, lowly forms of life amplify their variety mainly by reproducing in vast numbers (incidentally producing a lot of food for other life-forms in the process). Higher life forms use more subtle methods. They exist in much smaller numbers, but make up for this by their increased range of locomotion and individual adaptability. Their development of refined nervous systems and organs of perception, attuned to their place in the ecosystem, makes the variety available to each individual much higher.

Humans are not physically well-endowed as predators, but their mastery of fire and tools allowed them to compete in that natural niche for millions of years. Their acquisition of the skills of animal husbandry, agriculture and other technologies has increased their dominance over the other life forms on planet Earth to unprecedented levels.

Variety of the human brain

- *10,000,000,000 neurons*
- *Average of 10,000 interconnections from each neuron to others*
- *The human brain therefore has staggeringly huge variety*
- *We ought to be able to cope!*

© Cavendish Software Ltd. 1995, portions © Stafford Beer 1985

Just what we are doing with all that brain power isn't exactly clear!

Self-organizing Systems

- *Living organisms are notable for their ability to maintain their identity, in spite of perturbations in their environment*
- *Human organizations also have this characteristic*
- *These systems are **purposive***

© Cavendish Software Ltd. 1995, portions © Stafford Beer 1985

Living organisms and human organizations both share a capacity to maintain their identity in the face of pressures from their environment. This is not a question of obvious material continuity. It is estimated that every seven years, all the molecules in your body have been replaced by new ones, but you are still recognizably the same person.

What persists is the relationship between the components, not the components themselves. The ability of these systems to continuously re-create themselves, while being recognizably the same, is also known as *autopoiesis*. I will refer to this as the capacity for self-organization, because it is easier to spell, and describes this property well enough for the purpose of this discussion.

This ability to maintain identity is related to the fact that these systems have *purposes*. These purposes provide the framework for their maintenance of identity. Lack of purpose is usually indicative of the impending collapse of a self-organizing system.

Hierarchy of Purposes

- *Self-organizing Systems have a hierarchy of purposes*
- *However, they all share the need to remain **Viable***

© Cavendish Software Ltd. 1995, portions © Stafford Beer 1985

Self-organizing systems have many purposes, some of which may not be at all obvious. However, they all share the need to remain *Viable*. This simply means that they share the aim of continuing to exist, at least until the time when their purpose has been achieved.

Since this is a characteristic shared by all self-organizing systems, it makes sense to focus on this, and to examine what elements are necessary in order for a system to remain viable. *The Viable System Model* claims to reveal the underlying structures necessary for a system to meet this criterion of viability.

The VSM's proponents claim that all self-organizing systems conform to this model, even if the participants are unaware of this. However, understanding the VSM, and applying it, should make it possible to improve the organization's effectiveness, since it may currently only be viable by accident, rather than design.

Operation, Management & Environment

- *Self-organizing systems have:*
 - ◆ *elements which do things*
 - *Operations*
 - ◆ *elements which control the doers*
 - *Management*
 - ◆ *Surroundings in which they function*
 - *Environment*

© Cavendish Software Ltd. 1995, portions © Stafford Beer 1985

The variety in the surrounding Environment will always be greater than that in the Operation, which in turn will be greater than that in the Management of the Operation.

This gives rise to the following diagram:

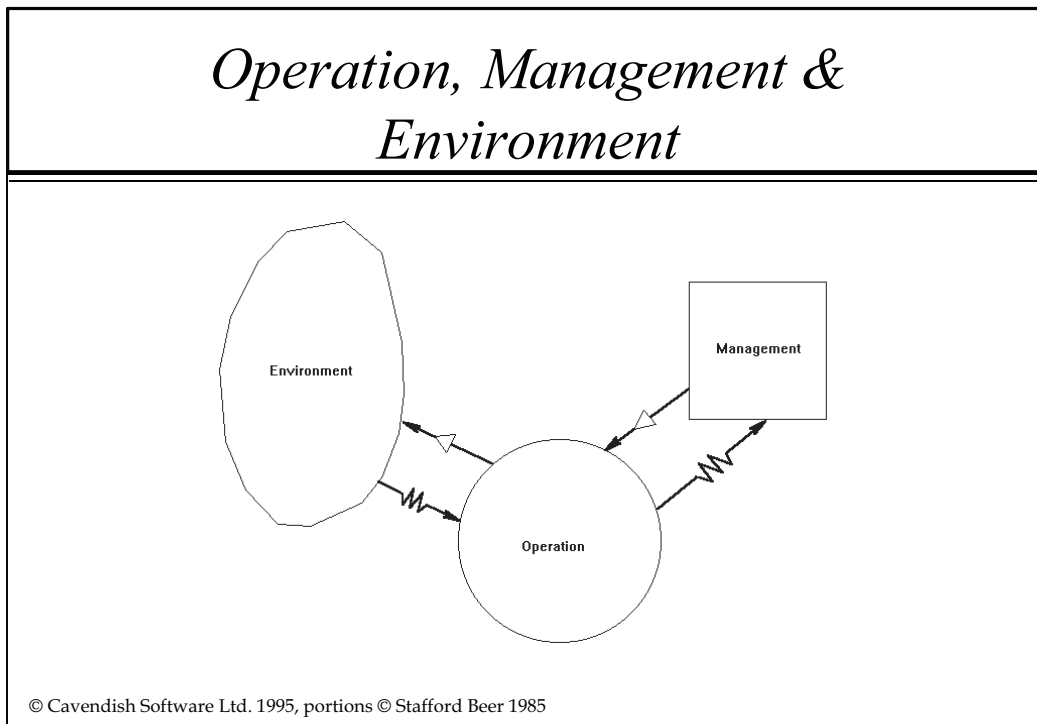

This diagram shows the variety channels which will be required between an Operation, its Management, and their Environment.

The diagram could be applied to a factory manufacturing a product to be sold into its market. In this case, one variety amplifier from the Operation to its Environment might consist of its advertising, and the variety attenuator in the opposite direction would be its market research. The Management variety amplifier would include such things as rewards for achievement, and punishments for failure. The corresponding variety attenuator would include production reports, and other management information.

The same diagram could be applied to the functioning of an organ, such as the heart, within the human body.

Since Management in practice is enclosed within the Operation, most of its information about the Environment arrives via the Operation, as shown. It may have direct channels to and from the Environment, but these will be discussed later.

Keeping Control - Homeostasis

- *In order to cope with its environment, the Operation needs to match its variety to that of the Environment*
- *In order to manage the Operation, Management needs to match its variety to that of the Operation*

© Cavendish Software Ltd. 1995, portions © Stafford Beer 1985

The Operation can cope with its Environment, as long as it can successfully absorb the variety from it, by attenuating the incoming variety, and amplifying its own variety back to it.

Likewise, Management can cope with the Operation as long as it can successfully absorb the variety from it, by attenuating the incoming variety, and amplifying its own variety back to it.

If these requirements are met, the system can maintain *Homeostasis*. This means it can maintain itself in a state of equilibrium. If these requirements are not met, the system will become unstable, eventually leading to its collapse.

In reality, the diagram as shown so far is inadequate. This is because systems such as that shown are found embedded within larger systems, for reasons which will become apparent later.

However, the requirement to maintain a balance of variety is a fundamental feature of self-organizing systems.

Ashby's Law of Requisite Variety

- *Control can be obtained only if the variety of the controller is at least as great as the variety of the situation to be controlled.*
- *In short, **Variety absorbs Variety***

© Cavendish Software Ltd. 1995, portions © Stafford Beer 1985

Stafford Beer considers *Ashby's Law of Requisite Variety* to be as important in the field of cybernetics as Newton's Laws of Motion are in dynamics.

Once understood, this law appears to be obvious. However, it is not very well known. If it was, it is very unlikely, for example, that Milton Friedman would have been given the Nobel Prize for Economics for his invention of monetarism. It is quite clear that attempting to control a complex economic system simply by manipulating the money supply defies *Ashby's Law of Requisite Variety*, and is therefore doomed to failure.

The experiments which were conducted in the 1980s to demonstrate this fact were carried out on a very large scale, and proved rather costly!

This Law directly yields Beer's First Principle of Organization:

First Principle of Organization

- *Managerial, operational and environmental varieties, diffusing through an institutional system, tend to equate; they should be **designed** to do so with minimal damage to people and to cost*

© Cavendish Software Ltd. 1995, portions © Stafford Beer 1985

This, like Beer's other principles of organization, is intended to provide a guideline for the practical *design* of human organizations, rather than being a statement of a law of nature.

Life's not that simple!

- **A viable system is more complex than the diagram we have seen so far**
 - ◆ *The heart cannot survive without the rest of the human being*
 - ◆ *Operational units are usually grouped within a larger organization*

© Cavendish Software Ltd. 1995, portions © Stafford Beer 1985

Viable systems invariably contain a number of Operations, each of which has an associated Management function, and operates in its own Environment.

For example, the human body has a heart, a liver, lungs, intestines, etc. Corporations contain a number of operational sub-divisions. In both cases, there are flows of information and materials between these Operational Units.

To be viable, these Operations need to co-operate with each other, and maintain a suitable state of balance between themselves.

In the human body, co-ordination is achieved by a number of methods, including signals sent along nerves and the adjustment of hormone levels in the bloodstream. The whole system is supervised by the nervous system and the brain.

In a corporation, co-ordination is achieved by, for example, production plans, and there are senior managers who oversee groups of operational sub-divisions. In the remainder of this presentation, I will concentrate on examples from human organizations, largely because this is of more practical value and relevance to the intended audience.

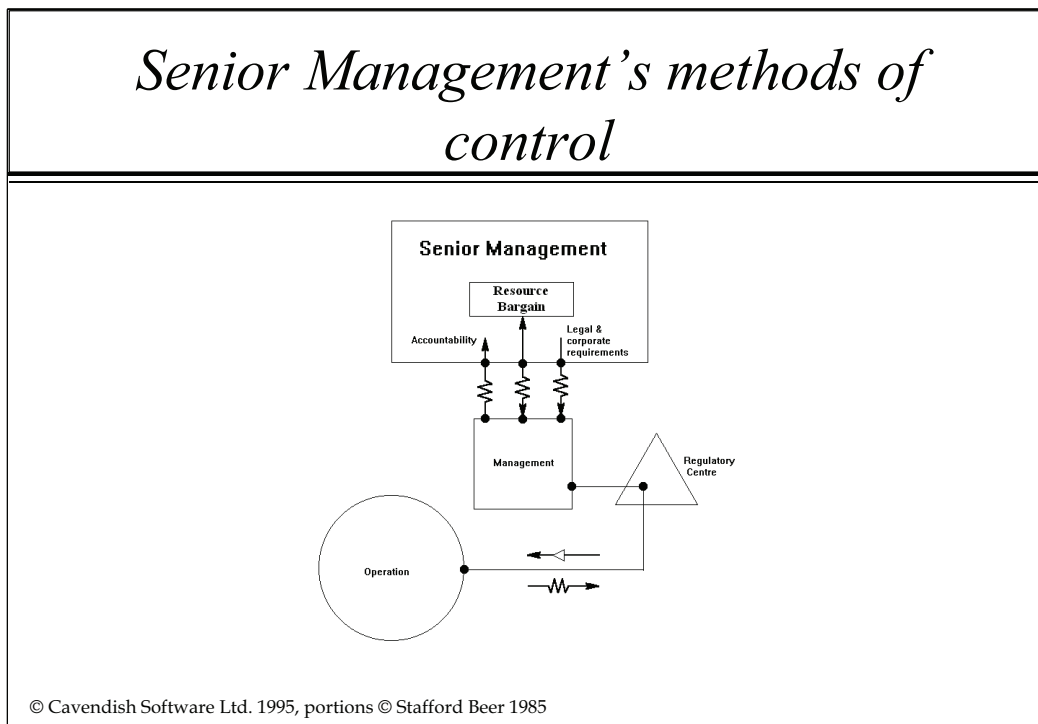

Senior management in a corporation controls the actions of operational management partly by striking a *Resource Bargain* with them. In other words, the management of each operation has to agree to carry out only certain of the actions possible to them in exchange for a share of the resources of capital, manpower and facilities which are available to the total system. This resource bargain constitutes a powerful attenuator of the variety which operational management could generate.

In exchange for resources, operational management have to be accountable for their actions to senior management. *Accountability* is another powerful attenuator of their variety.

In addition, senior management implement procedures to ensure that the operational management meet *Corporate & Legal Requirements*.

The above diagram omits the variety amplifier and attenuator between the operation and its management only for the sake of simplification. The diagram does however include a two-way channel between them via a *Regulatory Center*. This emphasizes the fact that management should control their operation mainly by regulation of their activity, rather than ad hoc intervention.

The meaning of the black circles on the variety channels will be explained later.

*All channels must have requisite
variety*

- *Senior management may dictate a policy to operational management*
- *This is useless if the channel fails to transmit this effectively*
- *Even if transmitted, it has to then be transformed into concrete action plans for the operation*

© Cavendish Software Ltd. 1995, portions © Stafford Beer 1985

It is vital that all communication channels have requisite variety to handle transmissions. In practice, this means that policy has to be effectively communicated to each operational management, which then has to have the means for translating this into more concrete action plans to be followed by the operation. The operation then needs effective channels to its environment. A breakdown at any point will lead to ineffective action.

The channels need to have higher capacity than the variety of the reports, schedules, and other entities being transmitted, in order to cope with errors in the transmission - e.g. illegible handwriting has to be allowed for.

This consideration leads to Beer's Second Principle of Organization:

Second Principle of Organization

- *The four directional channels carrying information between the management unit, the operation, and the environment must each have a higher capacity to transmit a given amount of information relevant to variety selection in a given time than the originating subsystem has to generate it in that time*

© Cavendish Software Ltd. 1995, portions © Stafford Beer 1985

This principle introduces a time element into the situation. Communication along the channels has to be fast enough to keep up with the rate at which variety is generated, otherwise the system will become unstable. The stability of the system is *dynamic*, not static.

The Third Principle of Organization is about what happens when information crosses a boundary between a channel and one of the other entities in the system:

Third Principle of Organization

- *Wherever the information on a channel capable of distinguishing a given variety crosses a boundary, it undergoes transduction; the variety of the transducer must be at least equivalent to the variety of the channel*

© Cavendish Software Ltd. 1995, portions © Stafford Beer 1985

Each entity in a self-organizing system has its own “language”. If you consider, for example, a company which manufactures cars, the language used by production engineers in trying to resolve a problem on the production line is quite different to the language spoken by the directors at a board meeting. These languages are likely to be mutually incomprehensible. The same applies to the language used out in the environment and that used in the operation itself.

Whenever a message crosses a boundary, therefore, it needs to be “translated” in order to continue to make sense. This process is called *transduction*. If the *transducer* does not have requisite variety, the message gets garbled or lost.

We have probably all heard the joke about the First World War message from the front which read “Send reinforcements, we are going to advance.” which ended up as “Send three and four pence, we are going to a dance.”. This is an example of failure in transduction. Another familiar example is where a message is taken by somebody’s secretary, then never gets any further.

Transducers are represented in VSM diagrams by circular blobs at the boundaries between channels and other entities.

Fourth Principle of Organization

- *The operation of the first three principles must be cyclically maintained through time without hiatus or lags*

© Cavendish Software Ltd. 1995, portions © Stafford Beer 1985

Beer frequently emphasizes that organizations tend to break up their management activities into epochs - monthly, quarterly and annual meetings, for example. He points out that the real world does not work like this. Management has to be a continuous process to cope with the rate of change in the environment. Management on this basis almost certainly does not have requisite variety to cope effectively with events.

This principle of organization explicitly refers to the need for communication and response to be fast enough to keep up with the rate of changes affecting the organization.

System One - Implementation

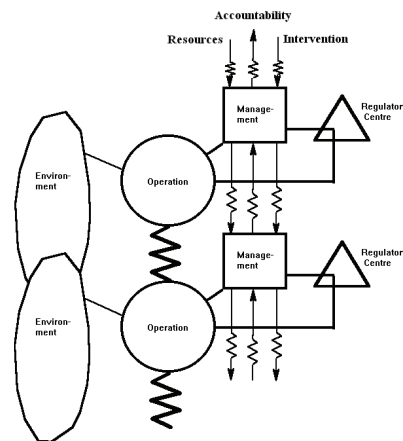

© Cavendish Software Ltd. 1995, portions © Stafford Beer 1985

Stafford Beer refers to the fundamental operations within a viable system as its *System 1*. This is also sometimes referred to as *Implementation*. System 1 is made up of all the operations which do the things which justify the existence of the system. It includes the managements of these operations. *It does not include senior management, which should be considered as a set of services to system 1.* Without system 1, there would be no reason for the organization to exist.

Previous diagrams have only considered a single system 1 entity. This diagram shows two system 1 entities, although a real organization would probably contain many more. Two way variety channels are depicted as a single line for simplicity in this diagram.

It is often the case that the environments of the operations overlap with each other. They are also connected to each other by such things as flows of materials. These connections are indicated by the thick squiggly line between them.

The position of the operations one above another is not significant. Also the vertical command channels go direct from senior management to each operational management - they do not pass through the other managements, but this is hard to depict on a flat sheet of paper.

System 1 in Steel Manufacturing

■ *Ore-mining*

◆ *Ore is transported to the iron-making plant*

■ *Iron-making*

◆ *Iron is transported to the steel-making plant*

■ *Steel-making*

© Cavendish Software Ltd. 1995, portions © Stafford Beer 1985

These transfers of material would be represented by thick squiggly lines between the operations.

These are not intended to represent variety attenuators.

Connections between System 1 operational units can vary enormously. In the above example, there is a close coupling between these. In other cases, there may be connections only of the form of “swapping notes” between, for example, regional operations of the same organization.

Environments for System 1 elements

- *These may completely overlap*
 - ◆ *Supermarket departments all sell to the same population*
- *They may be entirely separate*
 - ◆ *County councils within local government*
- *They may partially overlap*
 - ◆ *Sales regions, but one product is managed country-wide*

© Cavendish Software Ltd. 1995, portions © Stafford Beer 1985

Many variations on the relationships between System 1 elements' environments are possible, from total independence to complete overlap.

The need for co-ordination

- *System 1 elements may “get in each other’s way”*
- *This can cause oscillations in the system*
- *Therefore, co-ordination between them is essential*
- *Oscillations must be damped*

© Cavendish Software Ltd. 1995, portions © Stafford Beer 1985

In the steel-making example, poor co-ordination between ore-mining, iron-making and steel-making will lead to a stop-go situation, where production downstream is disrupted due to lack of materials.

In a school, it is essential that the same teacher is not scheduled to be teaching two classes at once, and that two classes are not scheduled to be in the same room at the same time.

Stafford Beer calls co-ordination features of a viable system *System 2*.

Classic examples of System 2 are a production plan, or a school timetable. These do not have to be imposed from senior management, but are usually arranged voluntarily between System 1 elements. Senior management only need to intervene to settle disagreements between the elements.

System 2 is embodied in the Regulatory Centers which were introduced in slide 24, and are represented as triangles in the diagram, as shown in the next slide:

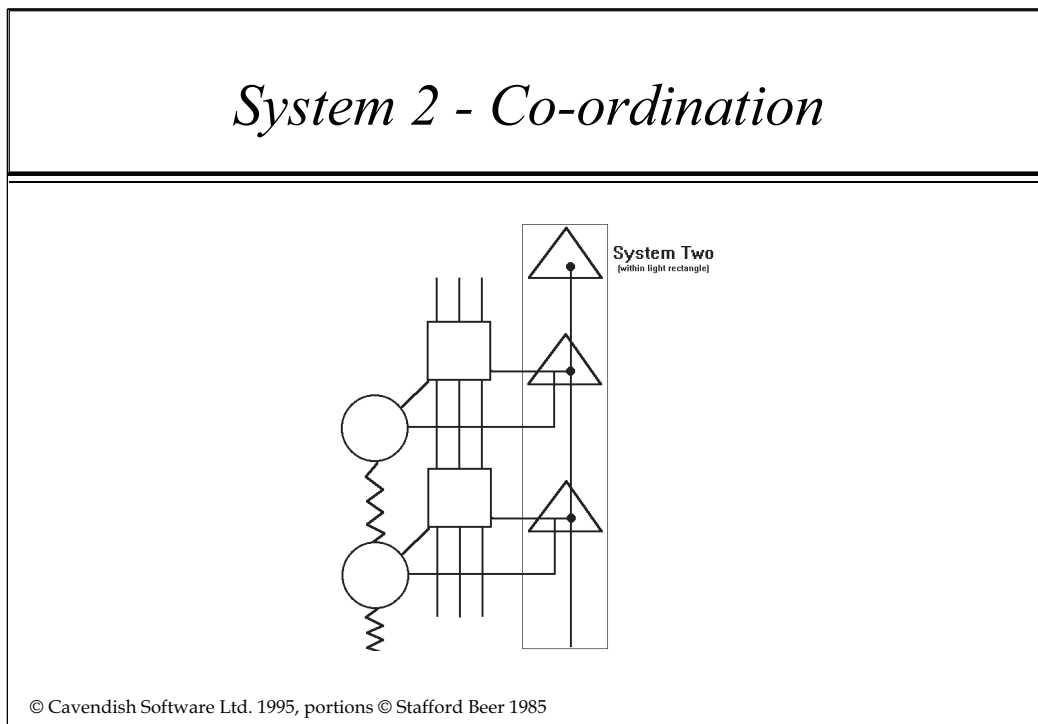

System 2 consists of a regulatory center for each element of System 1, and an overseeing regulatory center at senior management level.

It is very unlikely that senior management has requisite variety to dictate the operation of System 2. Most of this needs to be organized by the management of the system 1 operations.

In real organizations, a lot of System 2 activity takes place informally, over lunch or in the pub after work. A lack of comprehension of this important fact can lead to serious errors on the part of senior management. They can easily disrupt the operation of their organization by discouraging the informal links which enable it to run smoothly.

It has been suggested that Japanese companies work more smoothly than Western companies because staff are expected to socialize together for long hours outside their formal working hours. This gives ample opportunity for such informal links to operate. The cultural emphasis on consensus must also help this “damping of oscillations” by system 2.

Internal company newsletters can be a very effective System 2 tool.

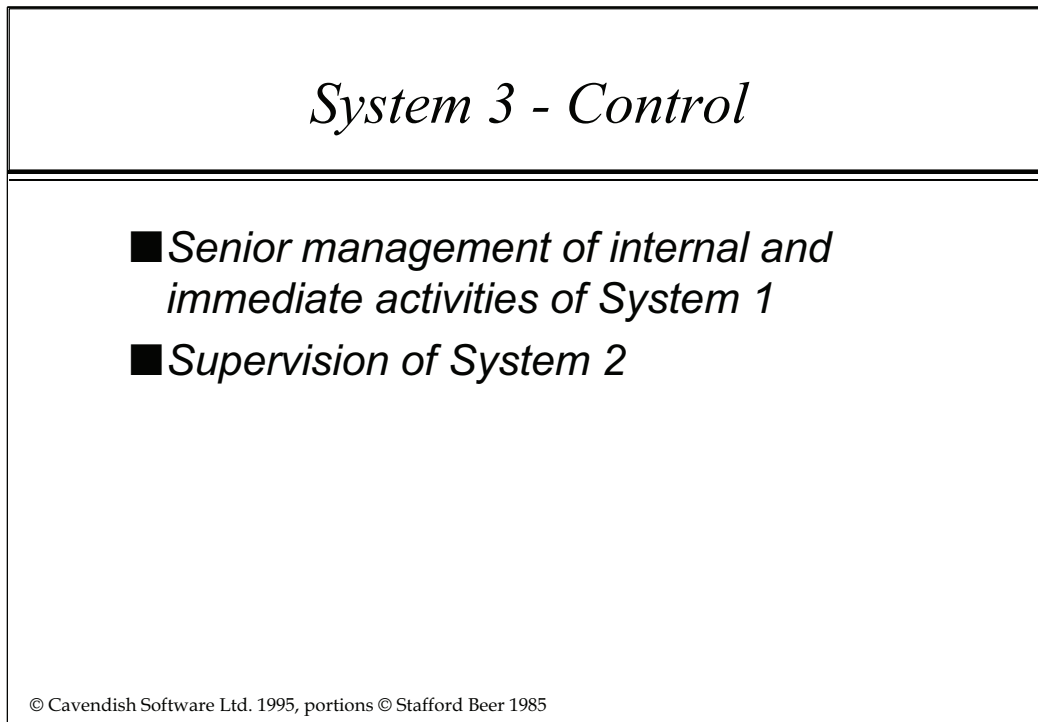

System 3 is Stafford Beer's term for the everyday control of System 1 by senior management. System 3 is responsible for internal and immediate control of the organization. It also supervises the coordination activities of System 2.

System 3 exerts control mainly using the vertical command channels shown on the diagram. However, control through these channels may not have requisite variety to be really effective. System 3 may need to directly monitor the operations of System 1, to ensure that System 1 management is not, either by accident or by design, "pulling the wool over their eyes". To do this, they may send task forces into the operations to carry out spot checks, audits, etc.

This is a very effective technique for maintaining System 3's requisite variety. Stafford Beer refers to these direct monitoring operations as System 3* (Three-Star).

First Axiom of Management

- *The sum of horizontal variety disposed by all the operational elements*
- **EQUALS**
- *The sum of vertical variety disposed on the six vertical components of corporate cohesion*

© Cavendish Software Ltd. 1995, portions © Stafford Beer 1985

This axiom basically states that surplus variety coming from the environment into the operation, then into the management of the operation, has to be canceled out by the variety coming down the vertical channels of System 3 and System 3*.

It is not necessary for variety to be strictly quantified in order for this to be achieved. The important thing is that variety coming from the left and bottom of the diagram is balanced by variety coming down and from the right. This is equivalent to saying that, if somebody is trying to push you over, you don't need to measure the force they are using, you merely need to ensure that you push back just as hard.

The system must be in *balance*. This is what Homeostasis is all about.

Measuring Authoritarianism

- *An organization's authoritarianism can be measured by comparing the variety exerted by System 1 management to that exerted by System 3*
 - ◆ *High street bank managers*
 - ◆ *Levels of stress amongst subordinates in modern businesses*

© Cavendish Software Ltd. 1995, portions © Stafford Beer 1985

Authoritarianism can be seen in the degree to which System 3 exerts detailed control over System 1 management.

In the United Kingdom, the last fifteen years has seen an increasing shift towards detailed control by System 3, at the expense of System 1. This is often made possible by information technology, and appears to be directed to maximizing profits for shareholders at the expense of other participants in the organization.

This trend is very clearly seen in the loss of autonomy experienced by, for example, the managers of branches of high street banks.

The trend expresses itself in high levels of stress amongst System 1 managers and workers.

Excessive centralization of control can be catastrophic, as recently witnessed in the collapse of the Soviet Union.

Looking outside & ahead

- *The organization needs a means of adapting to changing circumstances*
- *System 4 looks outside, and to the future*

© Cavendish Software Ltd. 1995, portions © Stafford Beer 1985

The organization as modeled so far is only capable of dealing with immediate concerns. In a changing world, organizations which fail to adapt cease to be viable, so an *intelligence* function is necessary.

System 4 fulfills this intelligence function. It requires an understanding of the total environment in which the organization is embedded, which is beyond the capability of System 1 units, since these concern themselves with only a sub-set of this total environment.

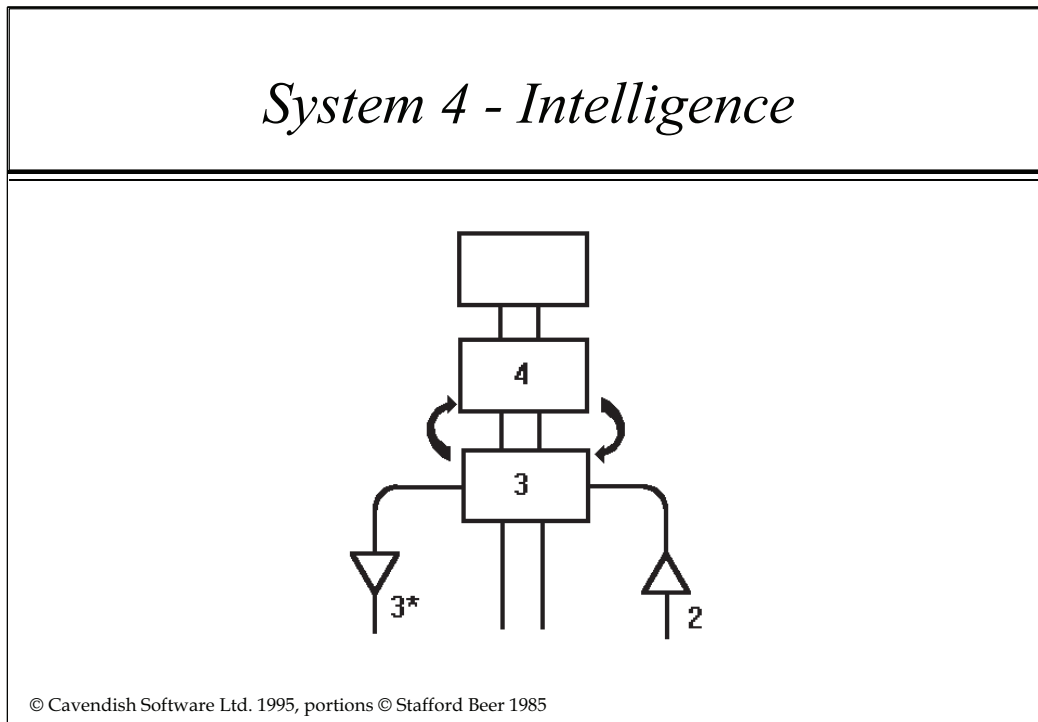

As well as channels out to the total environment (not shown above), System 4 needs channels to and from System 3. This is because intelligent adaptation cannot be achieved without an understanding of the organization as it currently exists, which is obtained via System 3. Adaptations of the organization then have to be fed back through System 3 in order to be implemented. The thick curved arrows between System 3 and System 4 are intended to indicate the very rich interaction that needs to exist between these two functions.

In fact, System 4 cannot do its job of intelligent adaptation *without containing a model of the whole organization, and its environment*. The quality of this internal model is crucial to the capability of the organization to adapt to change.

One of the key uses of the Viable System Model is as an aid to designing the model for System 4. In the early 1970s, Stafford Beer experimented with creating a VSM Operations Room to embody System 4 for the management of a national economy in real-time. The technology to do this is easily within the capabilities of modern personal computers.

Second Axiom of Management

- *The variety disposed by System Three resulting from the operation of the first axiom*
- **EQUALS**
- *the variety disposed by System Four*

© Cavendish Software Ltd. 1995, portions © Stafford Beer 1985

This axiom basically says that System 3 and System 4 must be in proper balance. As an example, it is useless to produce excellent products which are about to be rendered obsolete by new technology, but it is equally useless to do great research and development, but go out of business because you have nothing to offer to the market now.

System 4 is often very weak in real organizations. They are often much too busy struggling to cope with immediate problems to have time and resources to think about the future. Furthermore, when they are in trouble, System 4 activities are often the first to be cut back.

This is actually extremely dangerous, for reasons that ought to be clear by now.

Organizational Ethos

- *Every organization has its ethos, its distinctive identity*
- *The buck stops here*
- *This is where **policy** comes from*

© Cavendish Software Ltd. 1995, portions © Stafford Beer 1985

The intelligence function of an organization does not “think” in a vacuum. Every organization has an ethos which comes from somewhere. This somewhere is what Stafford Beer calls *System 5*, the overall policy making entity in the organization.

This provides the personality of the organization. This is sometimes the boss, but may not be. *System 5* is often highly distributed. For example, in schools in England, this function is partly exercised by the head & staff, and partly by the voluntary, unpaid body of school governors.

In the United Kingdom’s constitutional monarchy, this function is partly exercised by the unwritten constitution, the “rule of law” and partly by the monarch, who is “beyond politics”. In a republic it may partly be exercised by the Constitution, and partly by a president, who is also expected to be beyond everyday party politics, even though he may have been elected, as in France.

It is interesting to note that, historically, practically all republics where the president has direct executive power, without the counterbalancing effect of an “upper house” and constitution, have collapsed into tyranny. This happened to the first French Republic, Bolshevik Russia, and Weimar Germany. This may be because organizations which do not clearly distinguish between System 3 and System 5 are inherently unstable.

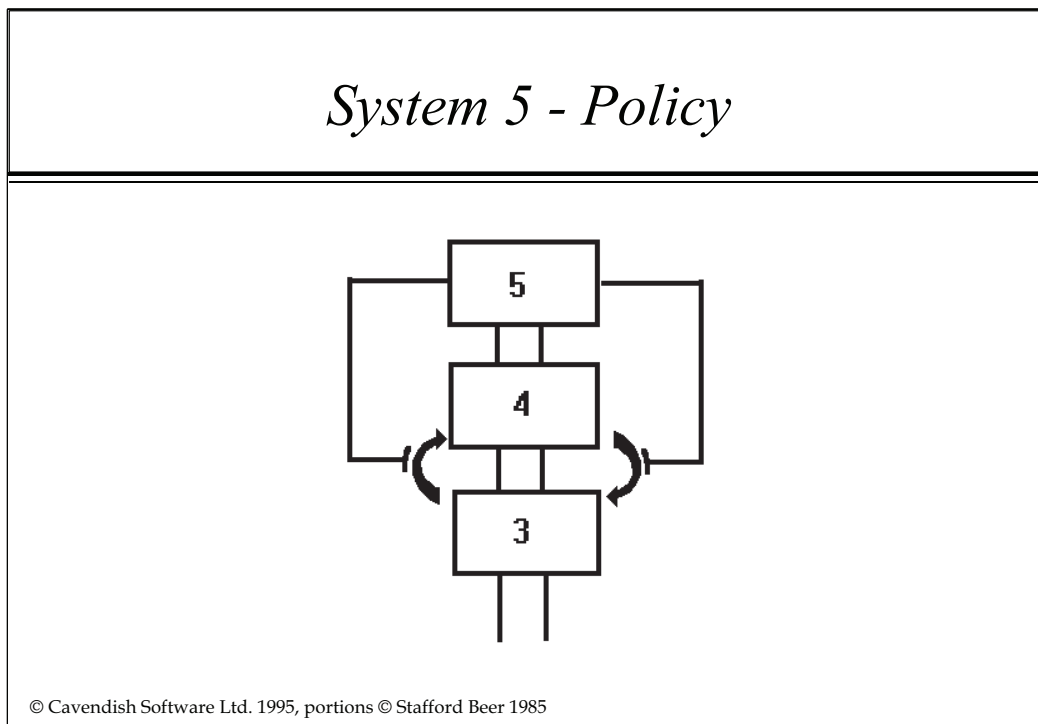

System 5's main roles are to:

- Supply logical closure to the viable system
- To monitor the System 3 - System 4 homeostat.

The former role effectively defines the identity and ethos of the organization - its personality and purpose.

The latter role maintains the balance between the management of "here-and-now" and the management of "out there and the future".

The combined structure of Systems 3, 4 and 5 can be said to be *metasystemic* to the combined structure of Systems 1, 2 and 3. This means the former grouping is logically "over and above" the latter.

System 3 forms the intersection of these two groupings, which makes sense, given that System 3 is usually thought of as running the whole organization.

Third Axiom of Management

- *The variety disposed by System Five*
- **EQUALS**
- *the residual variety generated by the operation of the Second Axiom*

© Cavendish Software Ltd. 1995, portions © Stafford Beer 1985

This axiom means that System 5 has to “soak up” any variety left unbalanced by the operation of the System 3 - System 4 homeostat.

This can be a big job. However, if the 3-4 homeostat is working well, there may be little for System 5 to do. Effectively, System 5 will continuously receive the signal that everything is ok. This is fine, as long as System 5 does not fall into a somnolent state, and fail to wake up when action is necessary.

All viable systems include a mechanism for overcoming this danger. This is referred to by Stafford Beer as the *algedonic* signaling system (from the Greek for pain & pleasure).

Algedonic Signals

- *Monitor the signals passing from System 1 to System 3*
- *If an emergency condition is detected, send a direct emergency signal to System 5*
- *This wakes System 5 up, to request emergency action by Systems 3 & 4*

© Cavendish Software Ltd. 1995, portions © Stafford Beer 1985

This mechanism is familiar to us in our own bodies. We get a pain if something serious has gone wrong somewhere in our System 1 elements.

Algedonic signaling systems can be designed to automatically alert higher level management to a serious problem, but only after first notifying System 1 management and giving them a chance to resolve the trouble.

Effectively, they can be designed to stop unnecessary prying by higher levels of management into affairs which should not concern them, while alerting them to serious lower-level malfunctions, where this is necessary.

This is an essential component of systems which preserve the autonomy of lower level recursions, while protecting against catastrophic failures. This technique can be used to resolve the issues of centralism vs decentralism, effectiveness vs freedom which plague debate about our organizations.

This almost completes the account of the Viable System Model:

The complete VSM diagram

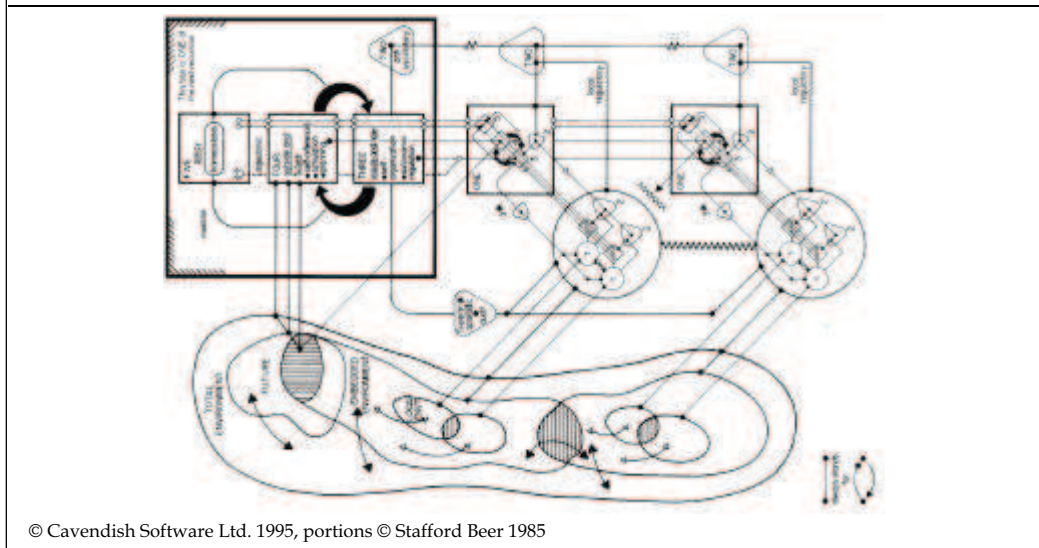

The above diagram shows the complete Viable System Model. Please note one very important feature of it (apart from the fact that it is on its side!):

- The model is *recursive*

This means that VSMs are nested inside each other. If you inspect the diagram, you will find that each System 1 entity contains a complete VSM at the next level of recursion down.

Conversely, each complete VSM at the current level appears as a System 1 entity at the next highest level of recursion. The combined System 3, 4 and 5 in particular appears as System 1 to the next level of recursion upwards.

This accords with experience. Corporations typically contain divisions, and are themselves participants in a particular industry. Individual participants in an organization are themselves viable systems in their own right.

As a viable system, a human being has his or her own Systems 5, 4, 3, 2 and 1.

The Law of Cohesion

- *The System One variety accessible to System Three of Recursion x*
- **EQUALS**
- *the variety disposed by the sum of the metasystems of Recursion y for every recursive pair*
- *where recursion x contains recursion y*

© Cavendish Software Ltd. 1995, portions © Stafford Beer 1985

This apparently opaque statement is actually a restatement of the First Axiom of Management for the general case, of VSMs nested within each other.

Important Points to Grasp

- *The functions described in the VSM do not have to correspond to job descriptions*
- *Several functions may be carried out by the same people*
- *However, they MUST be carried out*

© Cavendish Software Ltd. 1995, portions © Stafford Beer 1985

It is usually the case that System 3, 4 and 5 functions are carried out by the same individuals. This often leads to confusion, since these distinctions are not usually clearly understood.

Most senior managers have risen to the System 3 control function from a System 1 management role. They are often tempted to fall back into their earlier roles, thus appearing to the current System 1 management to be meddling in affairs which are none of their business.

A similar temptation for System 5 managers to fall back to the System 3 function is also frequent.

In some organizations, System 1 managers may themselves need to exercise System 2 and System 3 roles. It is important for them to understand which "hat" they are wearing at any time.

Uses of the VSM

- *Aid to diagnosing organizational problems*
- *Framework for Business Process Re-engineering*
- *Basis for new Information Technology Tools*
- *Political Reform?*

© Cavendish Software Ltd. 1995, portions © Stafford Beer 1985

Stafford Beer sees the VSM as a way to resolve the old conundrum of Organizational Effectiveness Vs Freedom. He does not accept the generally held view that the freedom of citizens is only possible where government is ineffectual, and badly informed.

This is why he has written books with titles such as "Designing Freedom"

Next Steps

- *Practical plans of action?*
 - ◆ *What markets are there for products and services based on the VSM?*
- *It works, so why is it not being used more widely?*
 - ◆ *Discuss!*

© Cavendish Software Ltd. 1995, portions © Stafford Beer 1985

Bibliography

- *Stafford Beer Classic Library*
 - ◆ *Recently republished collection of 6 books*
- *The Viable System Model*
 - ◆ *Edited by Raul Espejo & Roger Harnden*
- *All available from John Wiley & Sons*

© Cavendish Software Ltd. 1995, portions © Stafford Beer 1985

Stafford Beer is now working on ideas about how to stop System 3 and 4 decision-making from “running on rails laid down by the agenda of meetings”.

See his recently published book *Beyond Dispute, The invention of Team Syntegrity* for details. This is also published by John Wiley & Sons.

Stafford is now approaching 70 years old, and still going strong. Amongst other activities, he is Visiting Professor at both Manchester and Durham Business Schools, Research Professor at University College Swansea, and Adjunct Professor at the University of Toronto. Liverpool John Moores University has nominated him Honorary Professor of Organizational Transformation.

Much of what Stafford wrote in the 1960s and 1970s seems remarkably prescient. Unfortunately, his warnings at that time about the urgent need for institutions to be reformed went largely unheeded. Many of the consequences which he predicted have come about already.

The body of knowledge which is exemplified in his work remains largely unexploited in common practice. The need for action is, in my view, more urgent than ever before.